

Toronto Pearson
Neighbourhood Table Briefing
2020 Capital Maintenance Projects Update

April 30, 2020

2020 Capital Maintenance Projects Update

Keeping our airfield in top condition and in compliance
with regulatory and safety standards

Changes due to Covid-19

Traffic levels have decreased significantly as a result of measures to manage the pandemic.

The lower traffic levels have altered the anticipated impacts of the work, as well as the methodology.

1. The work periods and durations are under review, where possible work can be optimized and durations shortened
2. The order of the work has changed. As such the projects and phases are no longer sequential
3. We no longer anticipate a north-south configuration due to the work, apart from wind driven operations

Communications to Public

- Metroland Community Paper and Website Advertising (2 ad buys, March and April):

Mississauga News	Bloor West- Parkdale	North York Mirror
Etobicoke Guardian	Vaughan Citizen	Acton /Georgetown
Brampton Guardian	Milton Champion	Thornhill Liberal
- Dedicated project webpage on torontop Pearson.com
- Social media
- Paid digital advertising (web display, search ads and social media)
- GTAA's "Checking In" newsletter
- Media outreach to provide more information for community news coverage
- Elected Officials and Neighbourhood Table briefings (March 11th and 17th)
- Second round of Elected Officials and Neighbourhood Table briefings (April 27th and 30th)

Regular updates will continue to be delivered through the airport's social media and website (torontop Pearson.com) throughout the course of work.

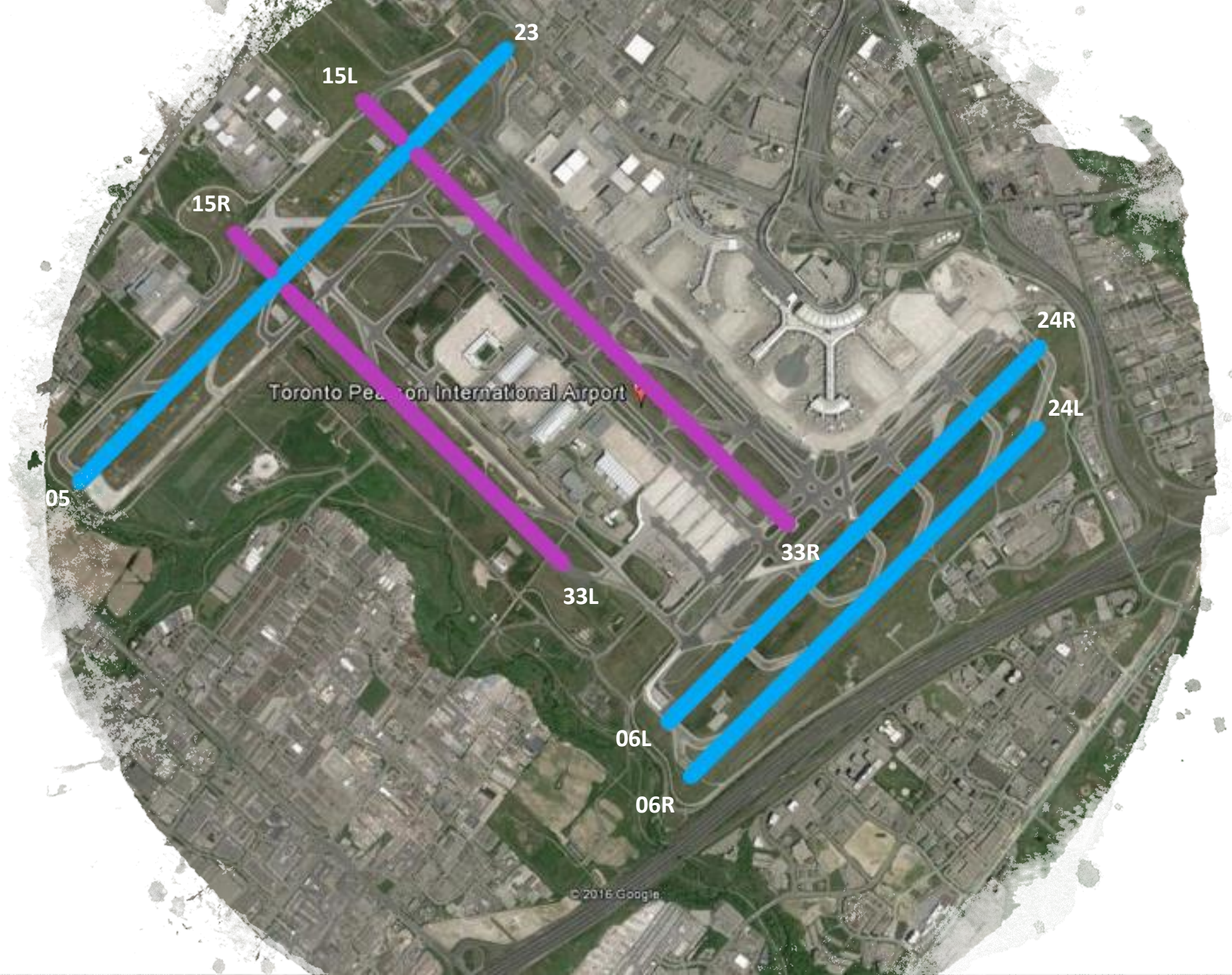

Toronto Pearson International Airport

23

15L

15R

24R

24L

05

33R

33L

06L

06R

© 2016 Google

East-West
North-South

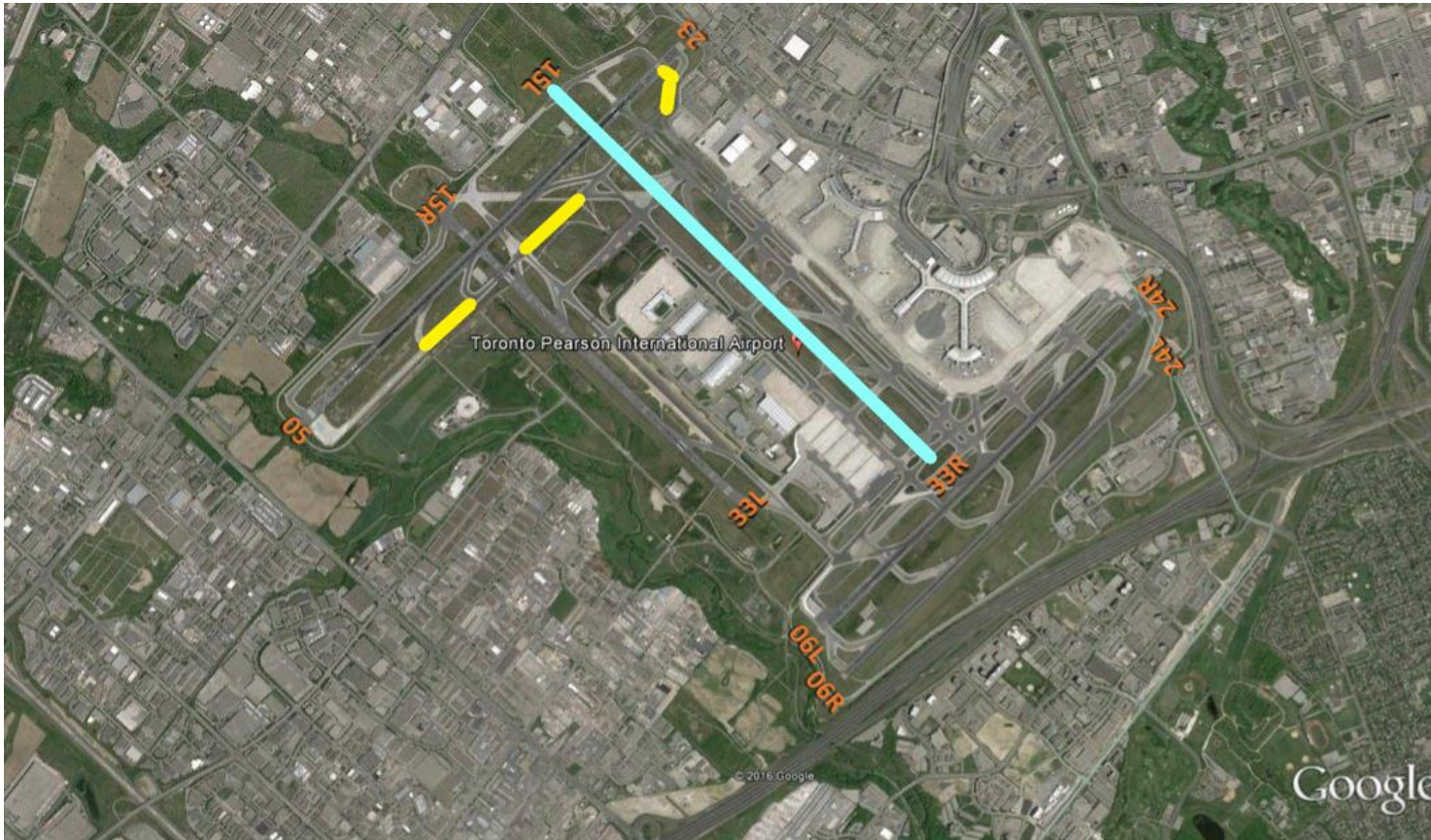

Main scope of Work:

- Rebuilding of Taxiway H (3 parts)
- Rehabilitation of Runway 15L/33R

2020 Airside Maintenance Projects

Timeline

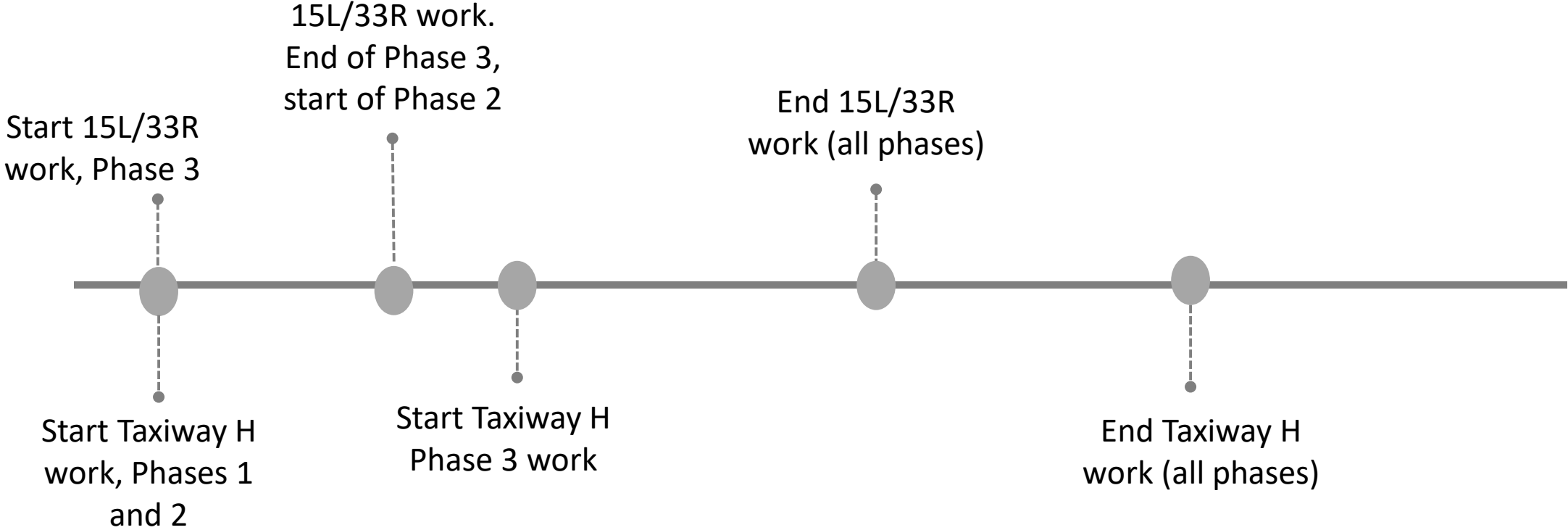

Project 2: Rehabilitation of Runway 15L/33R - Phase 3

Date: May 11th start

Duration: 10-14 days, 35 days and nights for all 3 phases combined

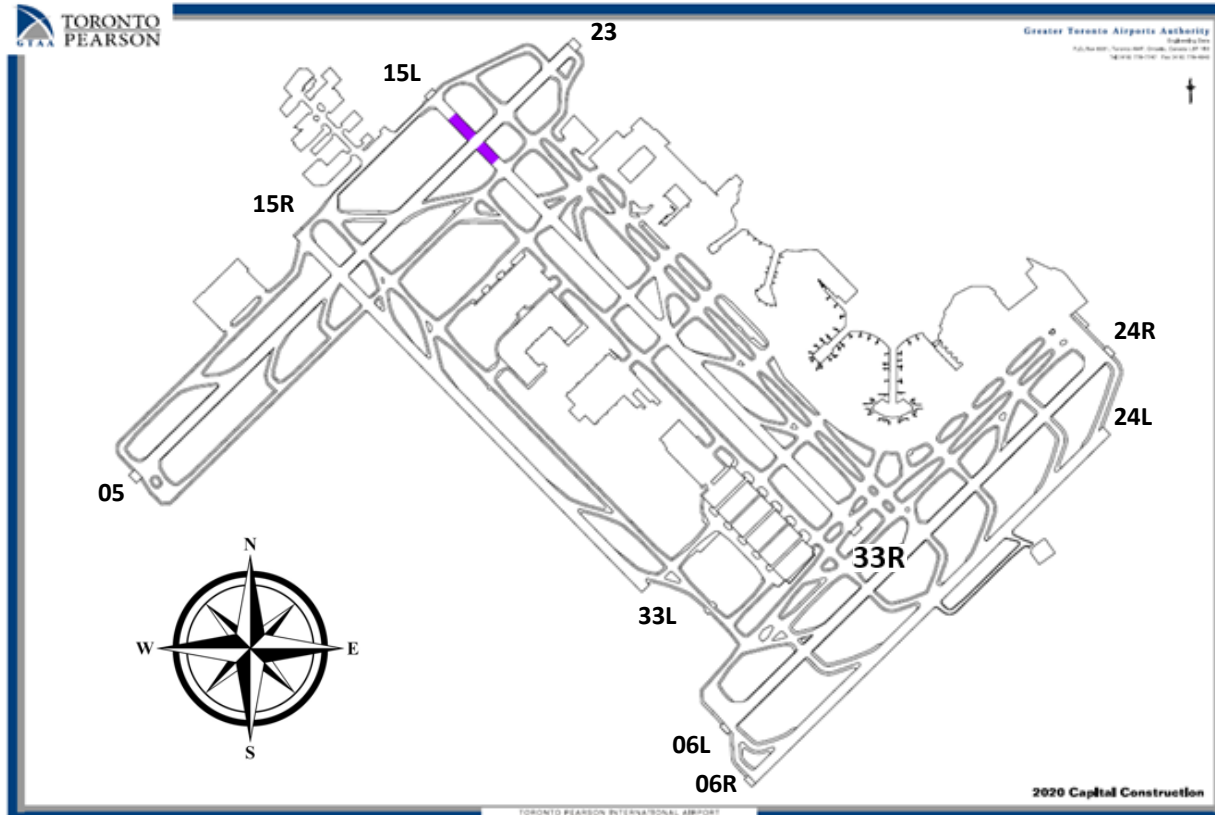

The Work

- Mill and pave work at the intersection of Runway 05/23 and Runway 15L/33R (highlighted area)
- Full closure of Runway 05/23 and Runway 15L/33R
- No recall on Runway 15L/33R
- One hour recall for Runway 23 departures (Runway 05 for winds)

Regular hours (6:30 a.m. to midnight) - The following land one depart one configurations are likely:

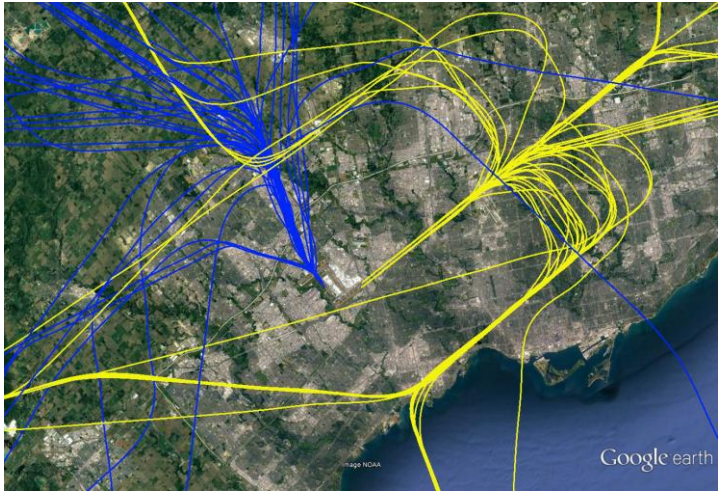

Arrivals on 24R and departures on 33L, arrivals on 06L and departures on 33L

- **East** – Etobicoke North, Etobicoke Centre, Humber River Black Creek, York Centre, Willowdale, Don Valley North, Markham-Thornhill, Markham-Unionville
- **West** – Mississauga-Malton, Mississauga East-Cooksville, Mississauga-Streetsville, Mississauga-Erin Mills, Mississauga-Centre, Milton
- **North** – Brampton East, Brampton Centre, Brampton North, Mississauga-Malton

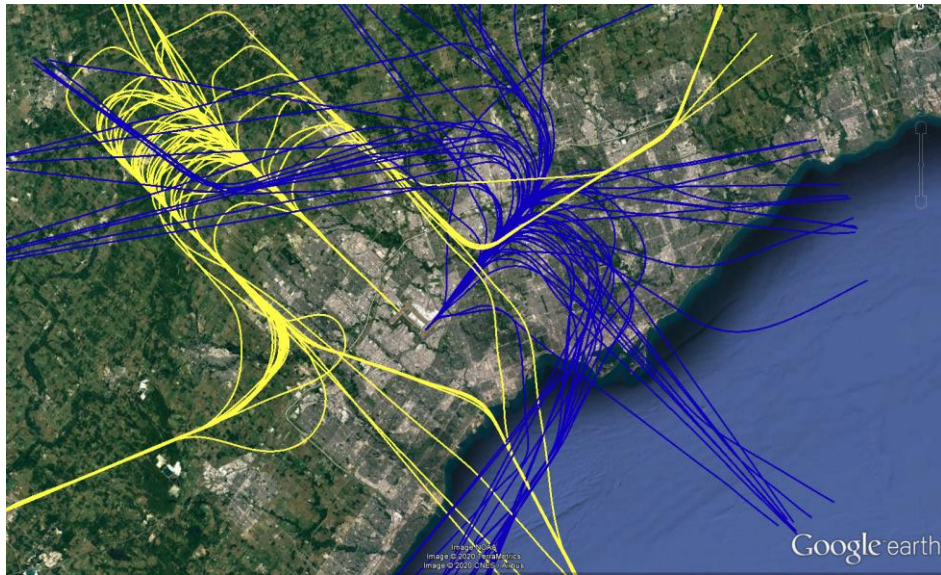

Arrivals on 15R and departures on 06L

- **East** – Etobicoke North, Etobicoke Centre, Humber River Black Creek, York Centre, Willowdale, Don Valley North, Markham-Thornhill, Markham-Unionville
- **North** – Brampton East, Brampton Centre, Brampton North, Mississauga-Malton

Regular hours (6:30 a.m. to midnight)

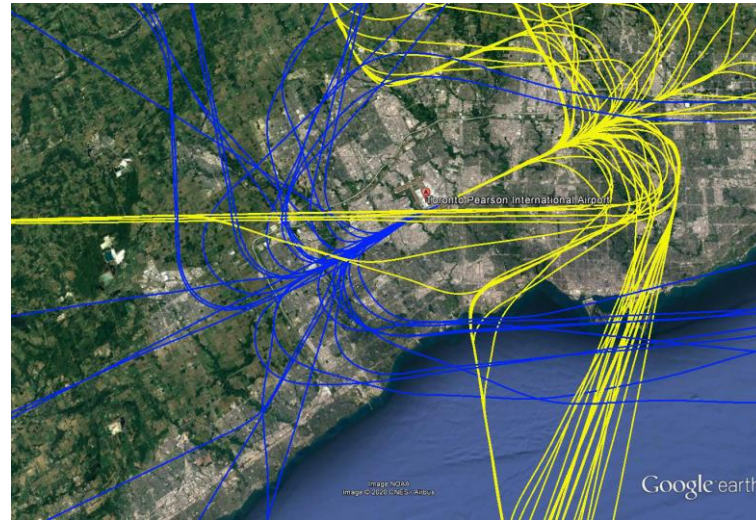
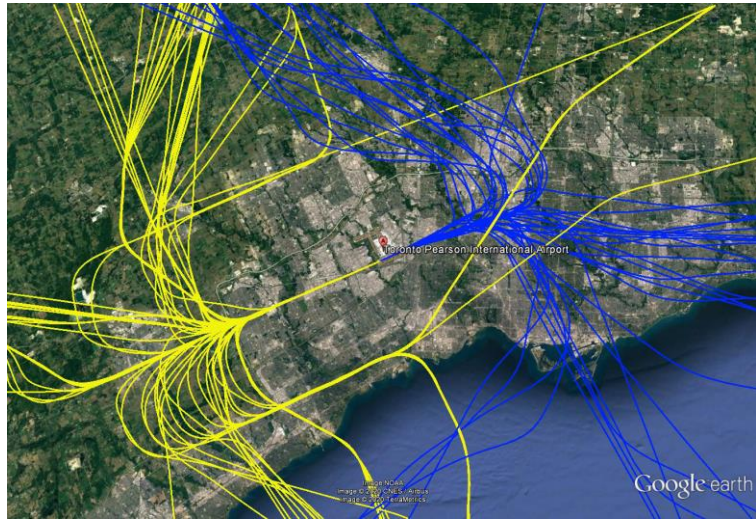

Arrivals and departures on 06L or 24R if required due to winds

- **East** – Etobicoke North, Etobicoke Centre, Humber River Black Creek, York Centre, Willowdale, Don Valley North, Markham-Thornhill, Markham-Unionville
- **West** – Mississauga-Malton, Mississauga East-Cooksville, Mississauga-Streetsville, Mississauga-Erin Mills, Mississauga-Centre, Milton

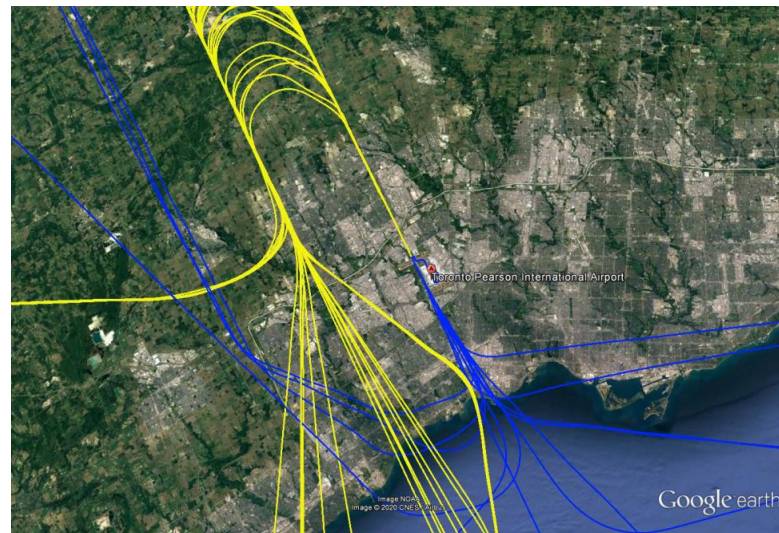
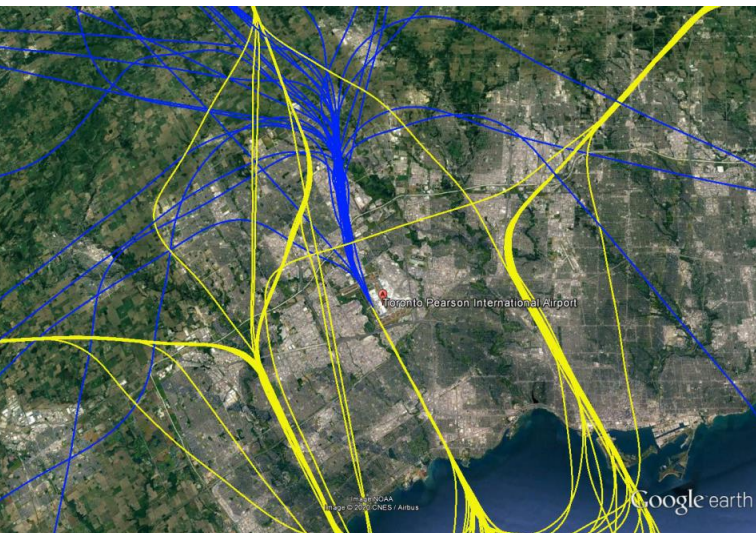

Arrivals and departures on 15R or 33L if required due to winds

- **North** – Brampton East, Brampton Centre, Brampton North, Mississauga-Malton
- **South** – Etobicoke Centre, Etobicoke-Lakeshore, Mississauga East-Cooksville

Preferential hours (midnight to 6:29 a.m.) - Increased use of maintenance contingency preferential runways

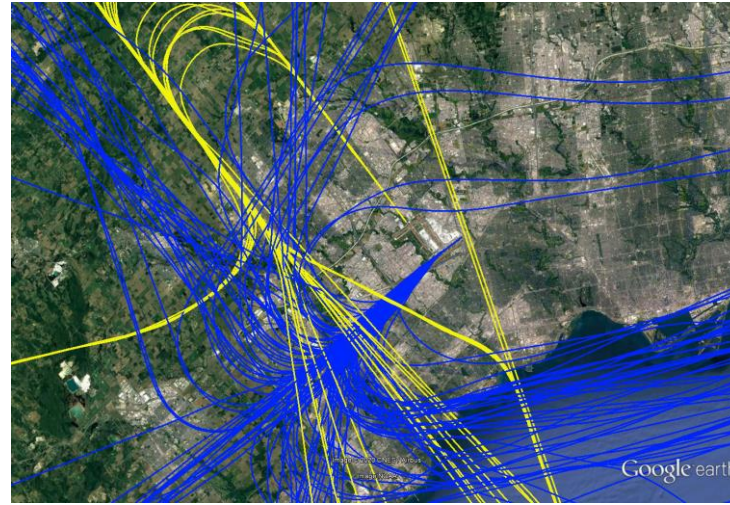
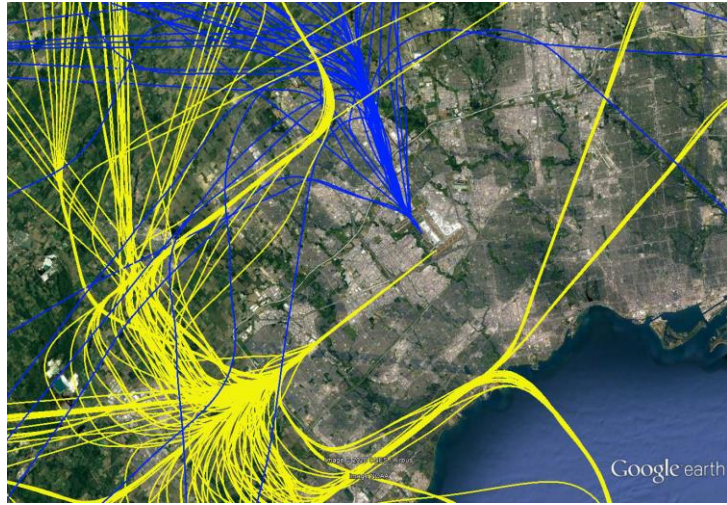

Arrivals on 06L and departures on 33L, arrivals on 15R and departures on 24R

- **West** – Mississauga-Malton, Mississauga East-Cooksville, Mississauga-Streetsville, Mississauga-Erin Mills, Mississauga-Centre, Milton
- **North** – Brampton East, Brampton Centre, Brampton North, Mississauga-Malton

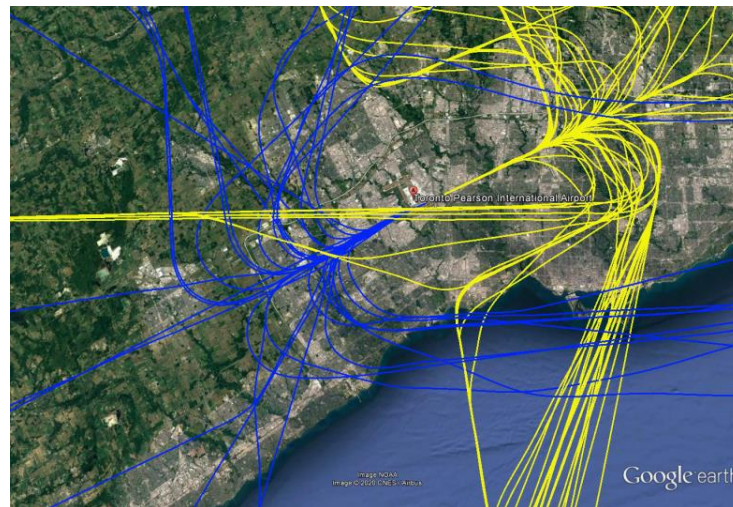
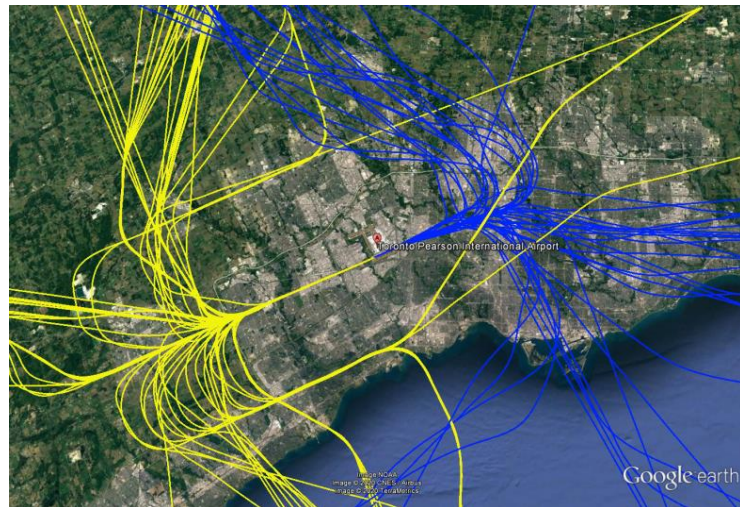

Arrivals and departures on 06L, arrivals and departures on 24R due to winds:

- **East** – Etobicoke North, Etobicoke Centre, Humber River Black Creek, York Centre, Willowdale, Don Valley North, Markham- Thornhill, Markham-Unionville
- **West** – Mississauga-Malton, Mississauga East-Cooksville, Mississauga-Streetsville, Mississauga-Erin Mills, Mississauga-Centre, Milton

Preferential hours (midnight to 6:29 a.m.) - Increased usage of maintenance contingency preferential runways

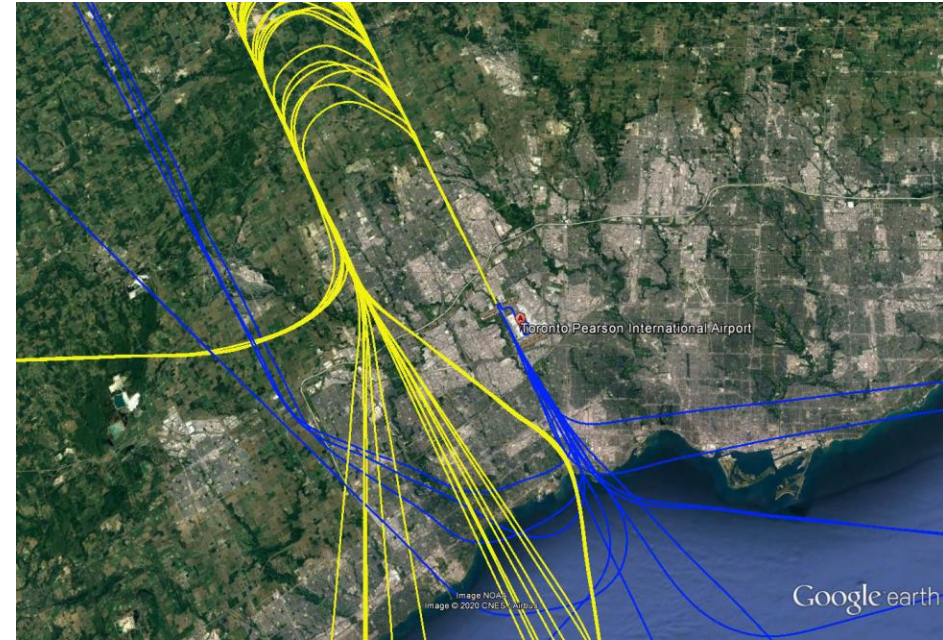
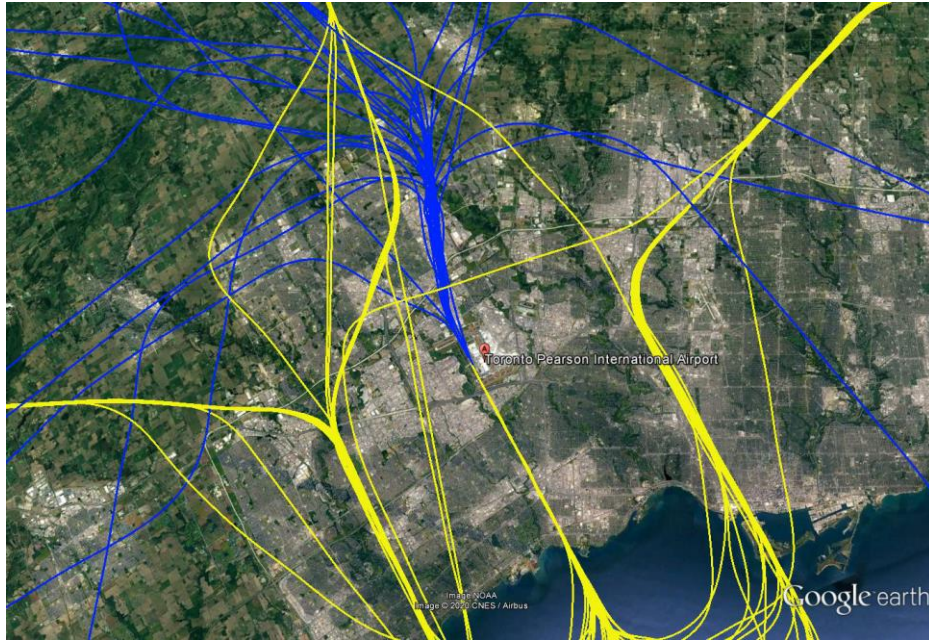

Arrivals and departures on 15R or 33L if required due to winds

- **North** – Brampton East, Brampton Centre, Brampton North, Mississauga-Malton
- **South** – Etobicoke Centre, Etobicoke-Lakeshore, Mississauga East-Cooksville

Project 1: Rebuilding Taxiway H – Phase 1

Date: Start May 11th

Duration: Approx. 9-10 weeks for phase 1 and 2 combined

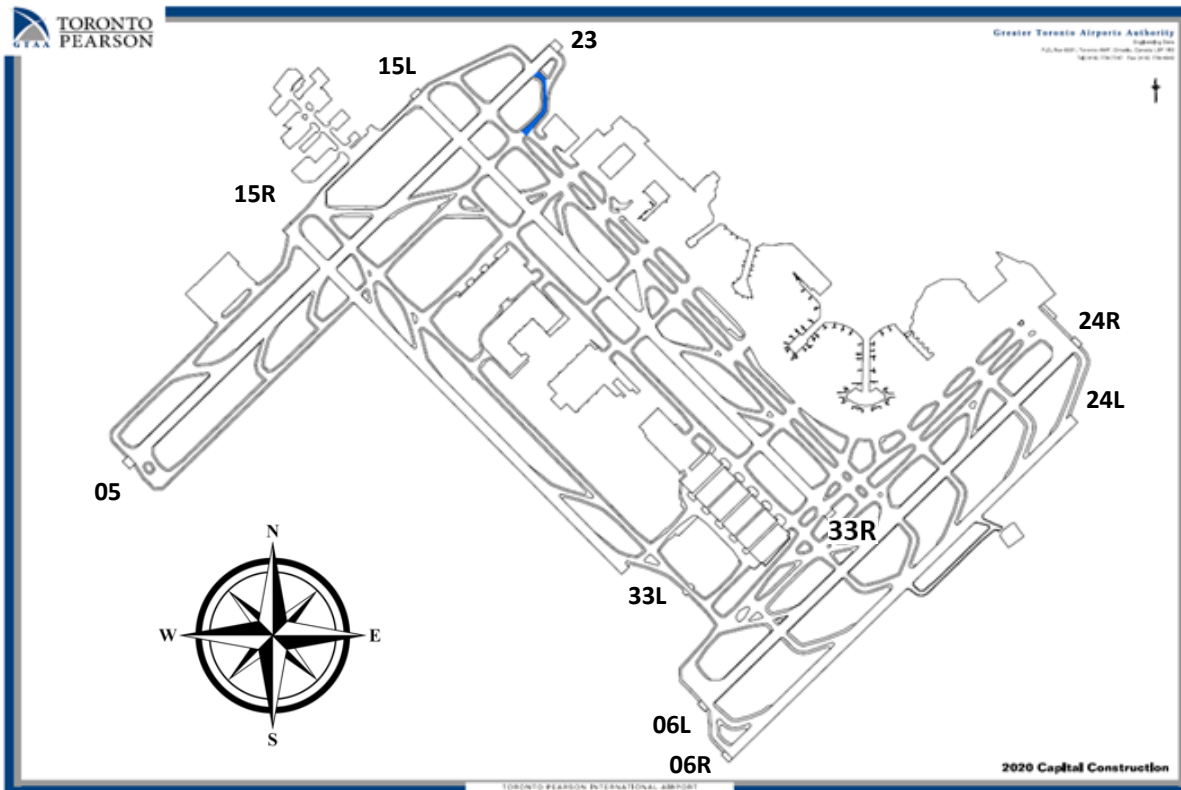

The Work:

- Replacement of concrete slabs on Taxiway H (highlighted area)
- Runway 05/23 departures will be shortened to 9,058ft for departures

Note phase 2 operations and impacts occur within phase 1 period (next slides)

Regular hours (6:30 a.m. to midnight) - For one-off long haul aircraft:

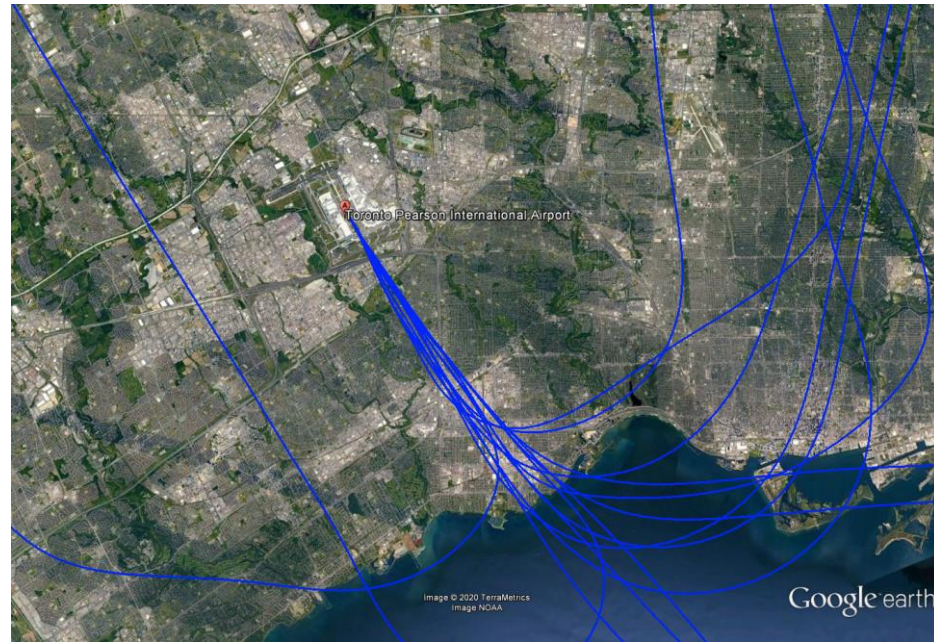
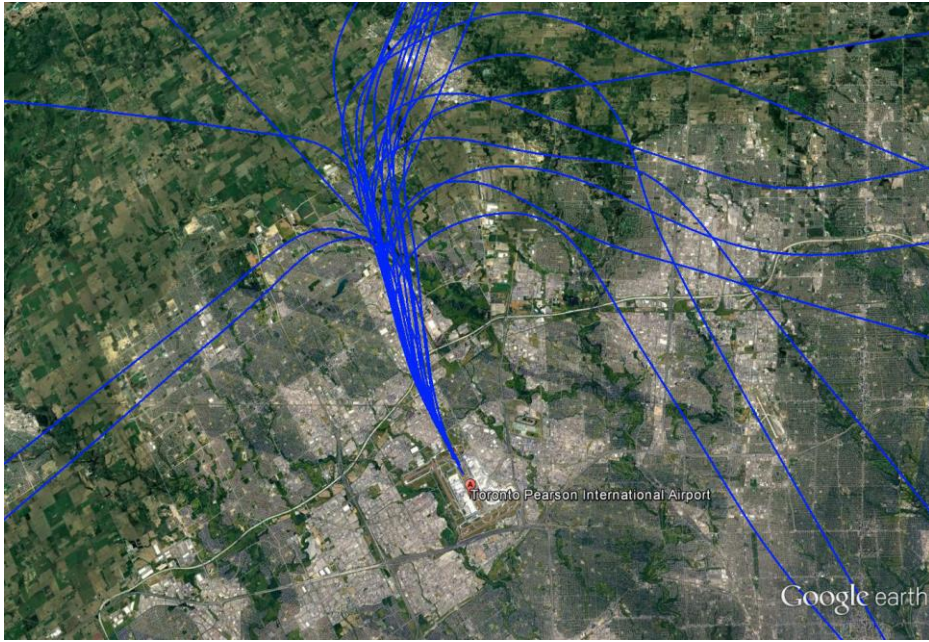

Departures off Runway 15L and 33R for one-off large aircraft requiring extra length

- **North** – Brampton East, Brampton Centre, Brampton North, Mississauga-Malton
- **South** – Etobicoke Centre, Etobicoke-Lakeshore, Mississauga East-Cooksville

Project 1: Rebuilding Taxiway H – Phase 2

Date: Start May 11th

Duration: Approx. 9 weeks for phase 1 and 2 combined

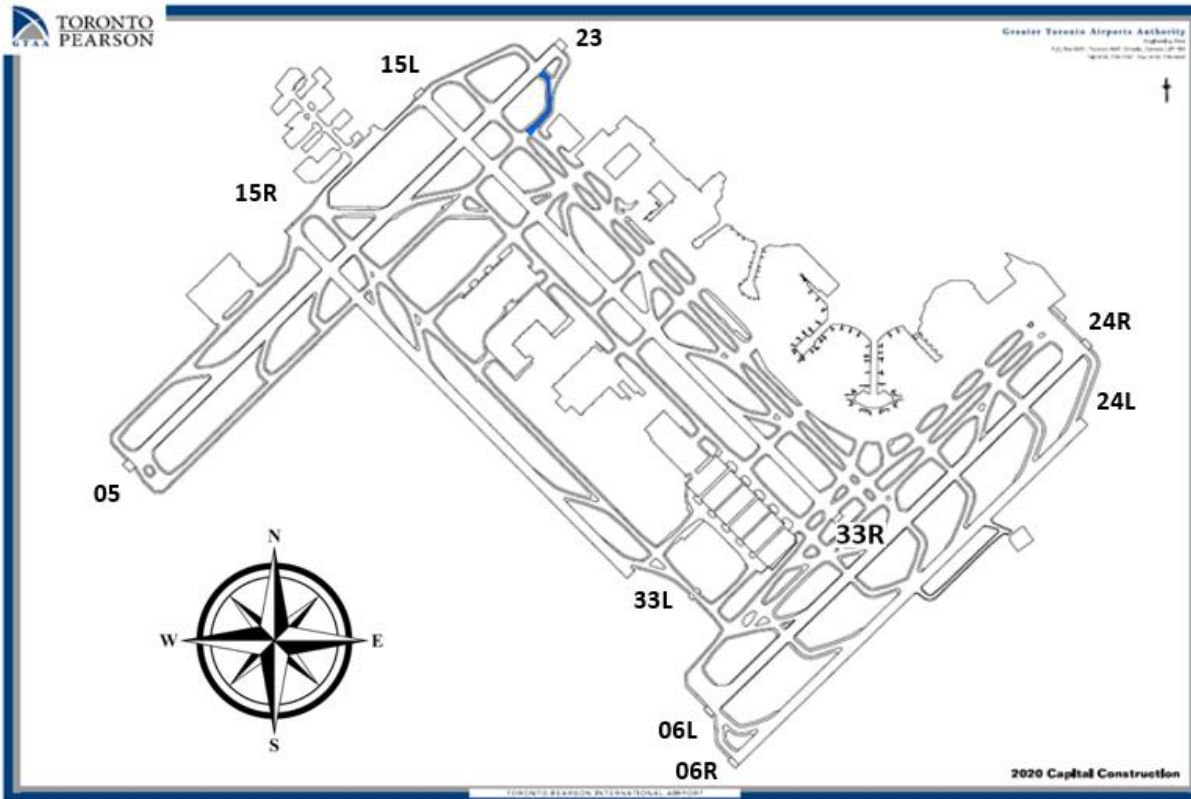

The Work

- Replacement of concrete slabs on Taxiway H (highlighted area)
- **This phase of the taxiway work involves a closure of Runway 05/23 when work is underway**

Preferential hours (midnight to 6:29 a.m.) - Increased usage of maintenance contingency preferential runways

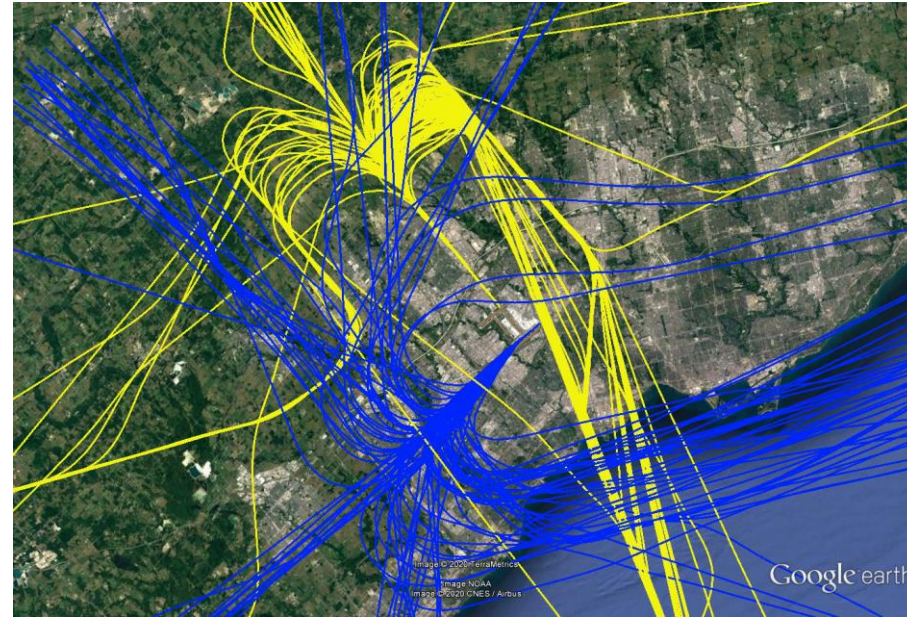
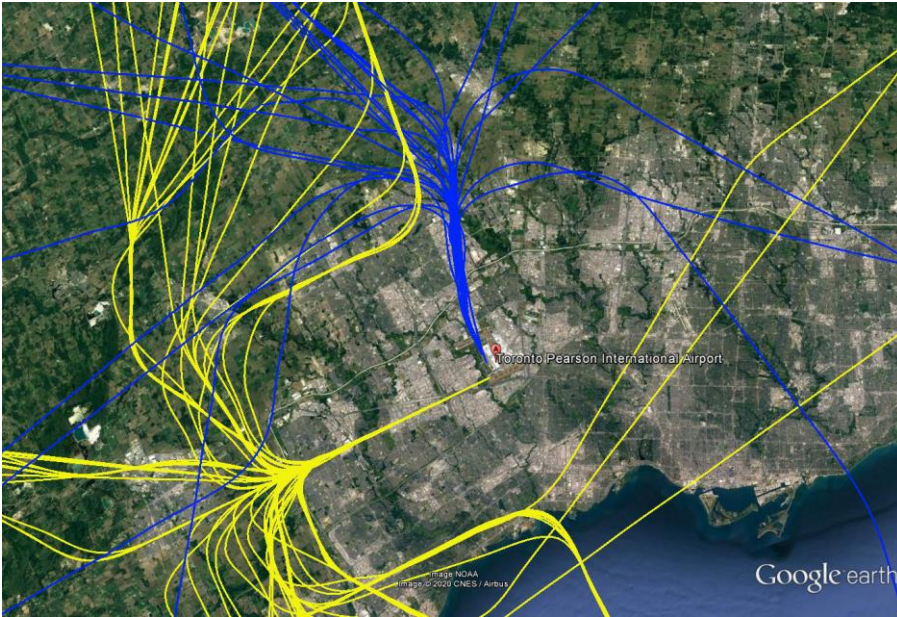

Arrivals on 06L and departures on 33R, Arrivals on 15L and departures on 24R

- **West** – Mississauga-Malton, Mississauga East-Cooksville, Mississauga Streetsville, Mississauga-Erin Mills, Milton
- **North** – Brampton East, Brampton Centre, Brampton North, Mississauga-Malton

Preferential hours (midnight to 6:29 a.m.) - Increased use of maintenance contingency preferential runways

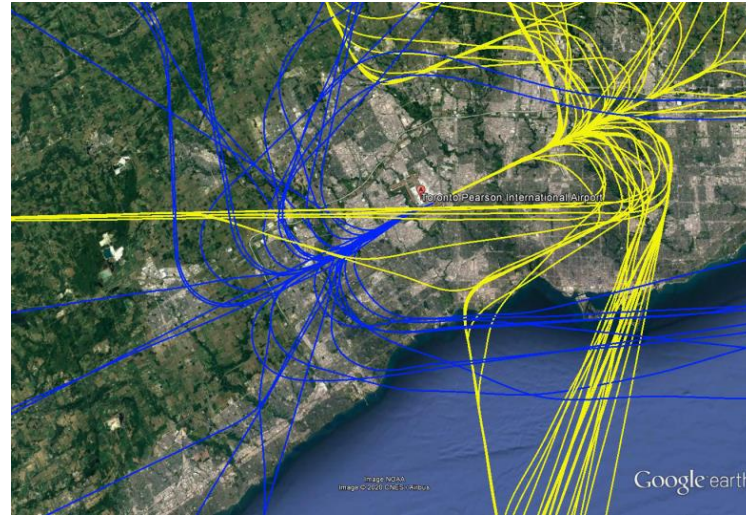
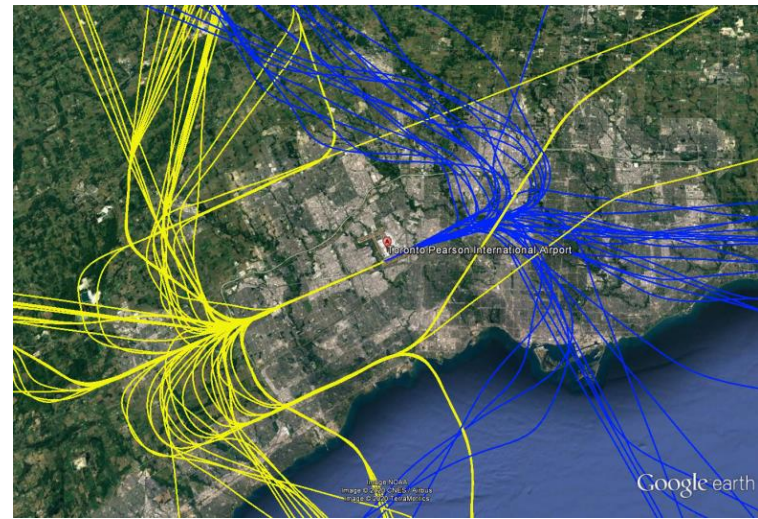

Arrivals and departures on 06L or 24R if needed due to winds

- **East** – Etobicoke North, Etobicoke Centre, Humber River Black Creek, York Centre, Willowdale, Don Valley North, Markham-Thornhill
- **West** – Mississauga-Malton, Mississauga East-Cooksville, Mississauga-Streetsville, Mississauga-Erin Mills, Milton

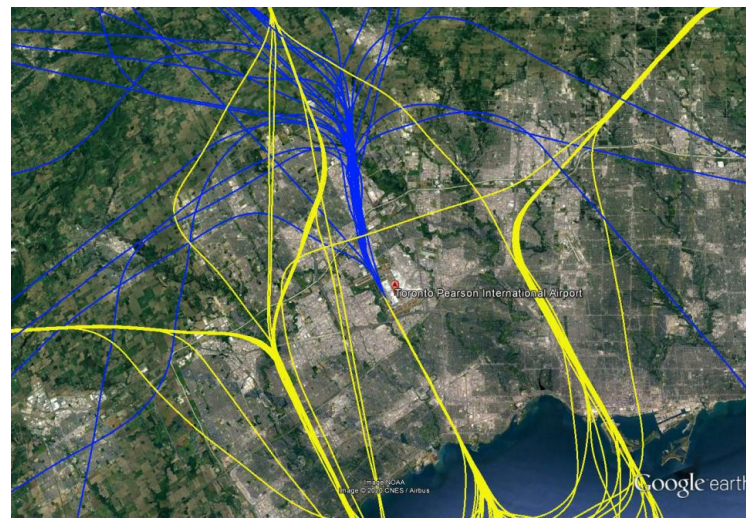
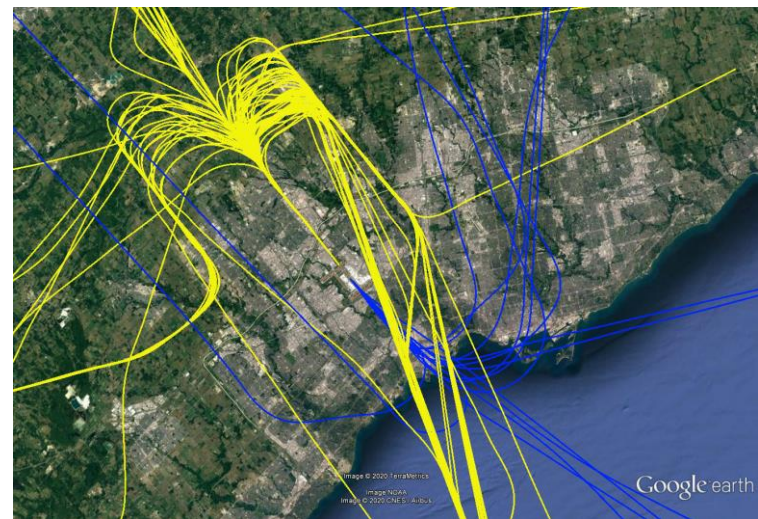

Arrivals on 15L and departures on 15L if needed for long haul flights due to length OR arrivals 33L and departures 33R if required by winds

- **North** –Brampton East, Brampton Centre, Brampton North, Mississauga-Malton
- **South** – Etobicoke Centre, Etobicoke-Lakeshore, Mississauga East-Cooksville

Project 2: Rehabilitation of Runway 15L/33R - Phase 2 (Purple)

Date: Start after completion of phase 3, approx. mid to late May start

Duration: 35 days and nights for all 3 phases combined

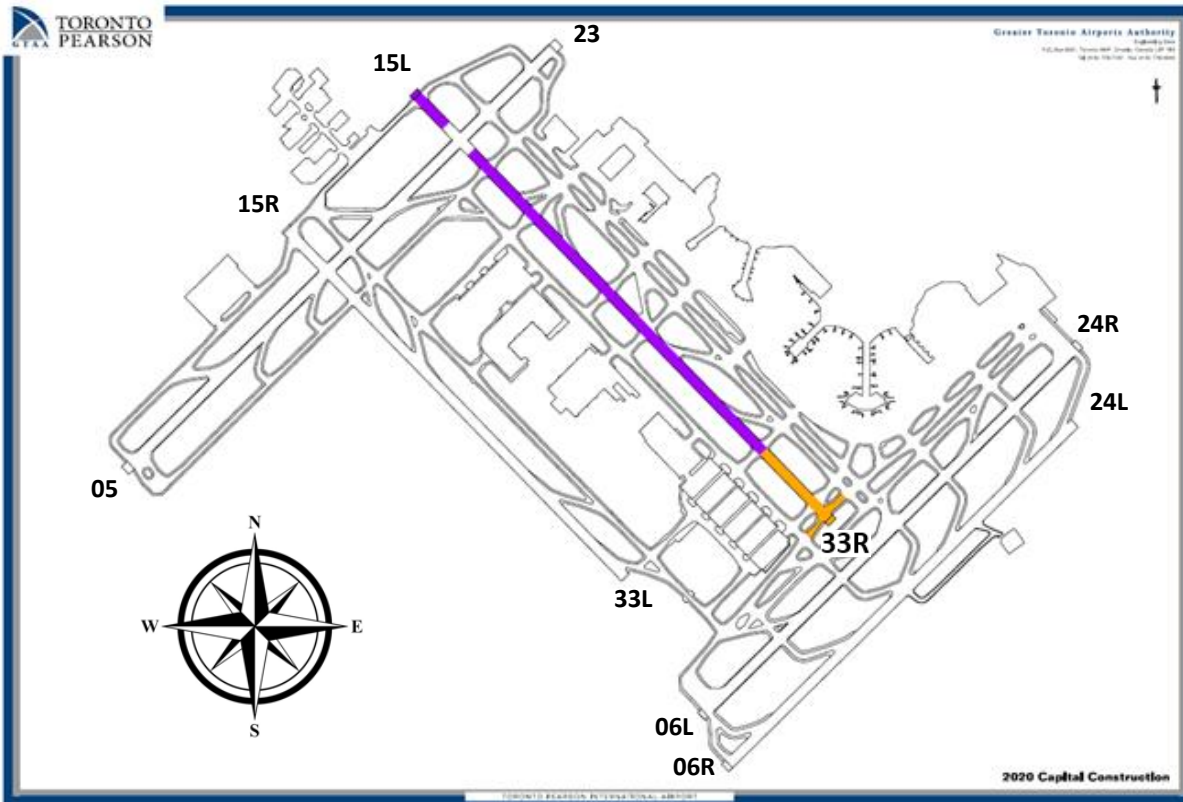

The Work

- Full length mill and pave of the runway to maintain a safe and stable surface
- This runway will not be available for use, there is no recall
- Arrivals and departures on 15R or 33L if required by winds

Regular hours (6:30 a.m. to midnight) Typical east/west operation expected

In the case of a wind driven north/south operation:

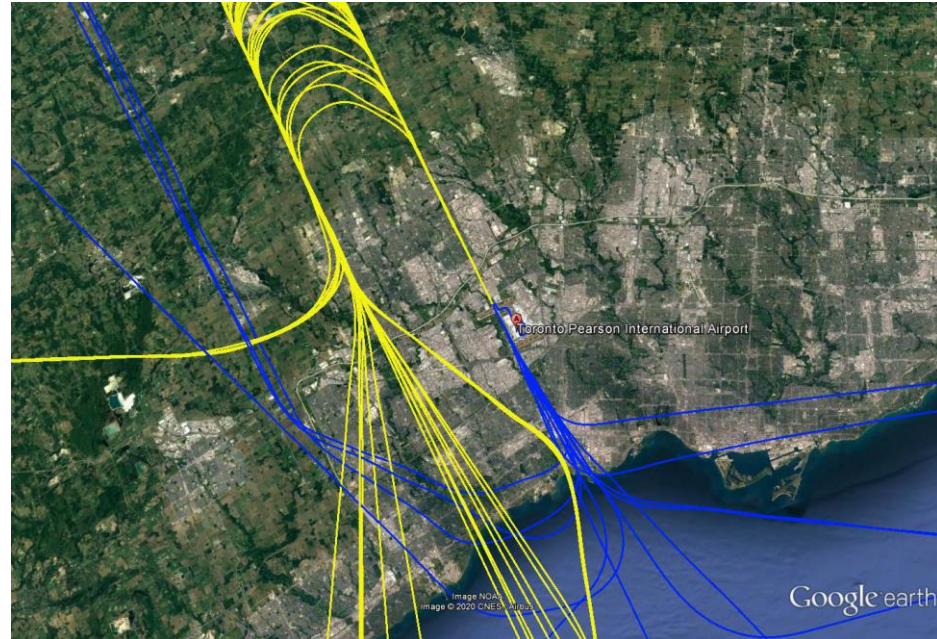
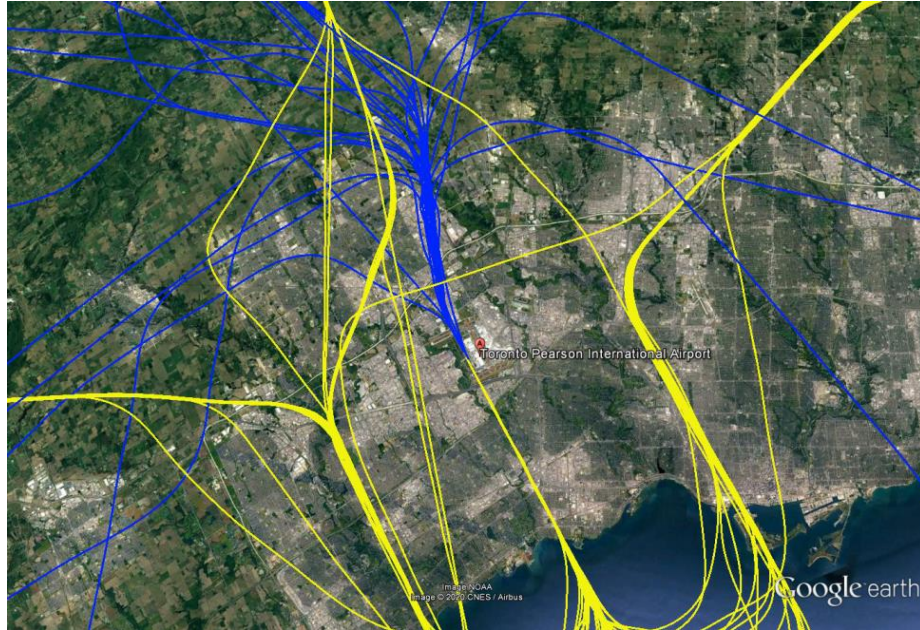

Runway 15R/33L only would be used for north/south operations if required due to winds

- **North** – Brampton East, Brampton Centre, Brampton North, Mississauga-Malton
- **South** – Etobicoke Centre, Etobicoke-Lakeshore, Mississauga East-Cooksville

Preferential hours (midnight to 6:29 a.m.) - Increased usage of maintenance contingency preferential runways

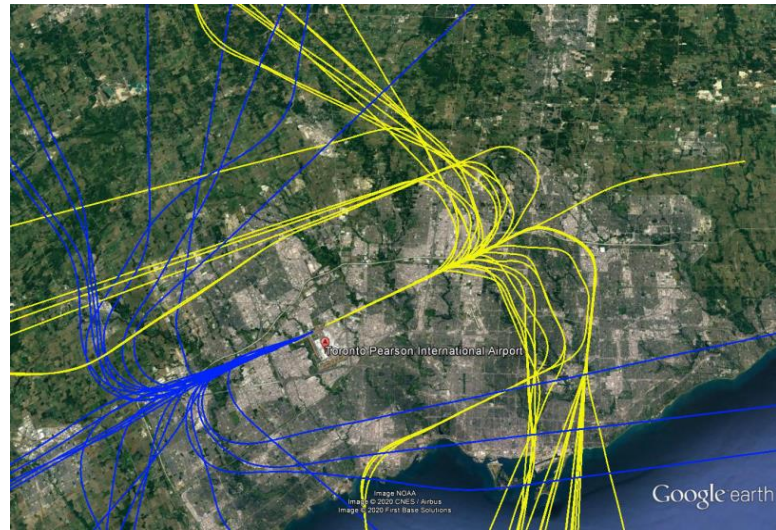

Arrivals and departures on 05 or 23

- **East** – Etobicoke North, Humber River Black Creek, Vaughan Woodbridge, Willowdale, Thornhill, Richmond Hill, Markham Unionville
- **West** – Mississauga-Malton, Mississauga-Streetsville, Mississauga-Erin Mills, Brampton South, Milton

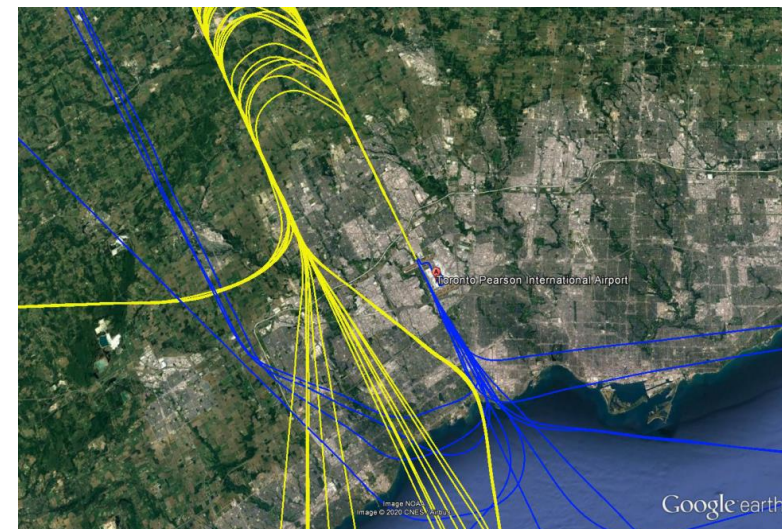
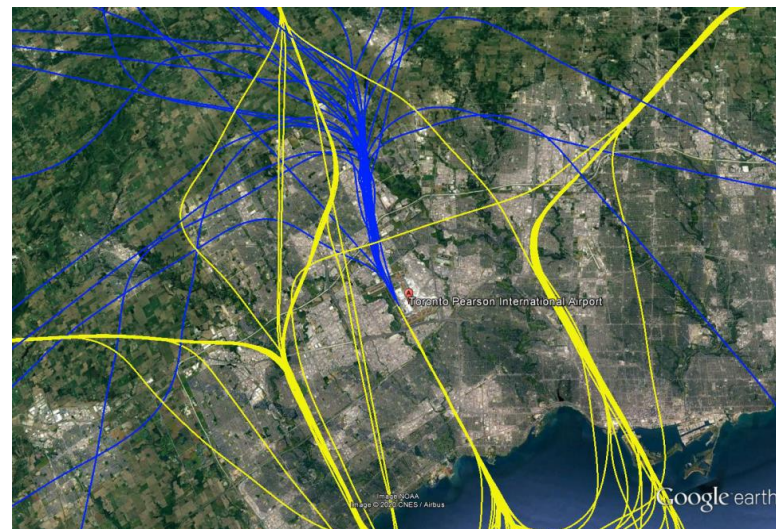

Arrivals and departures 15R or 33L if required by winds

- **North** – Brampton East, Brampton Centre, Brampton North, Mississauga-Malton
- **South** – Etobicoke Centre, Etobicoke Lakeshore, Mississauga East-Cooksville

Project 1: Rebuilding Taxiway H – Phase 3

Date: Start earliest May 31st

Duration: 5-6 weeks

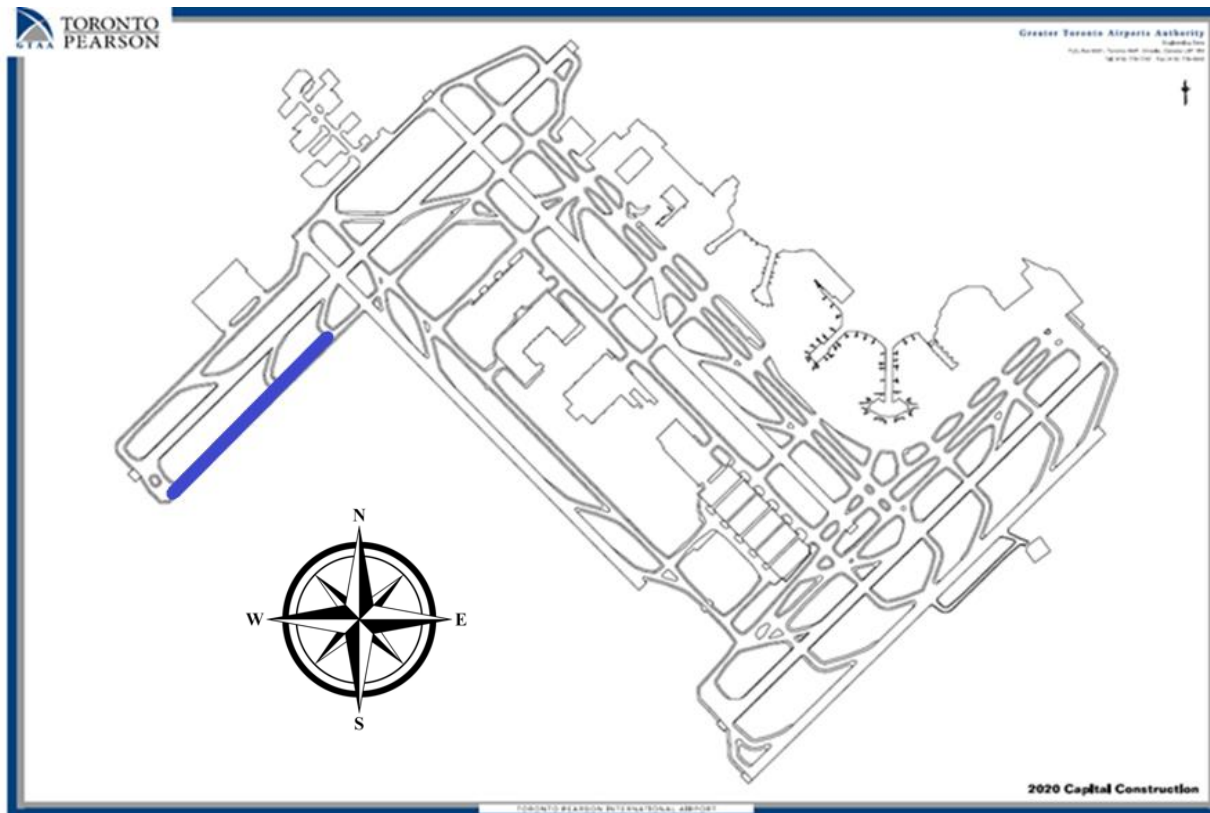

The Work

Continued repairs on Taxiway H

This phase of work affects access to/from Runway 05/23 for both arriving and departing aircraft.

Regular hours (6:30 a.m. to midnight) - The following configurations may occur:

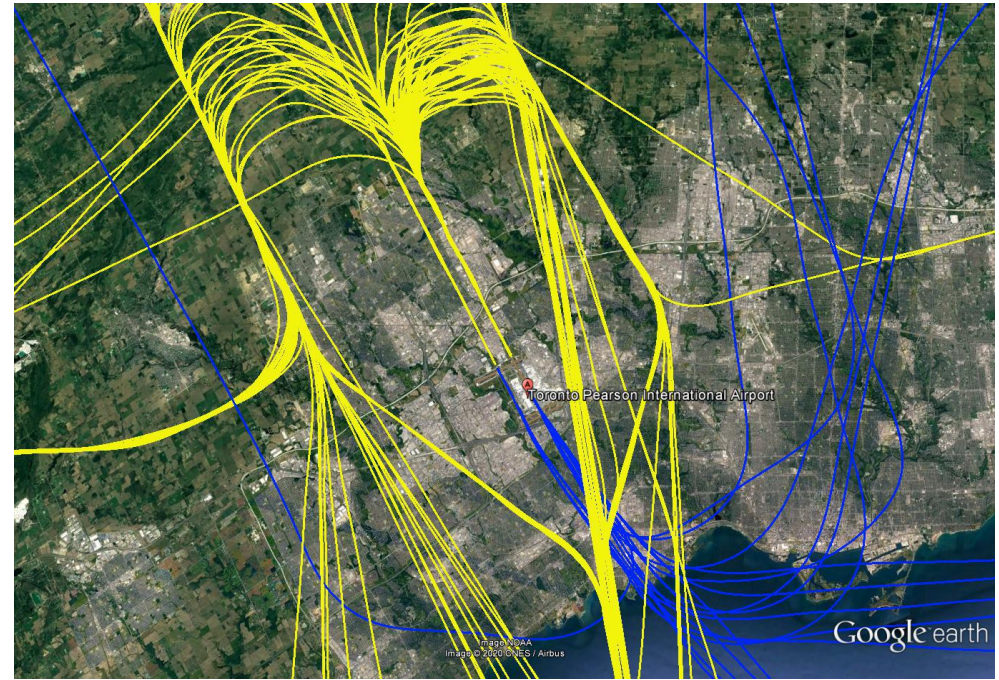
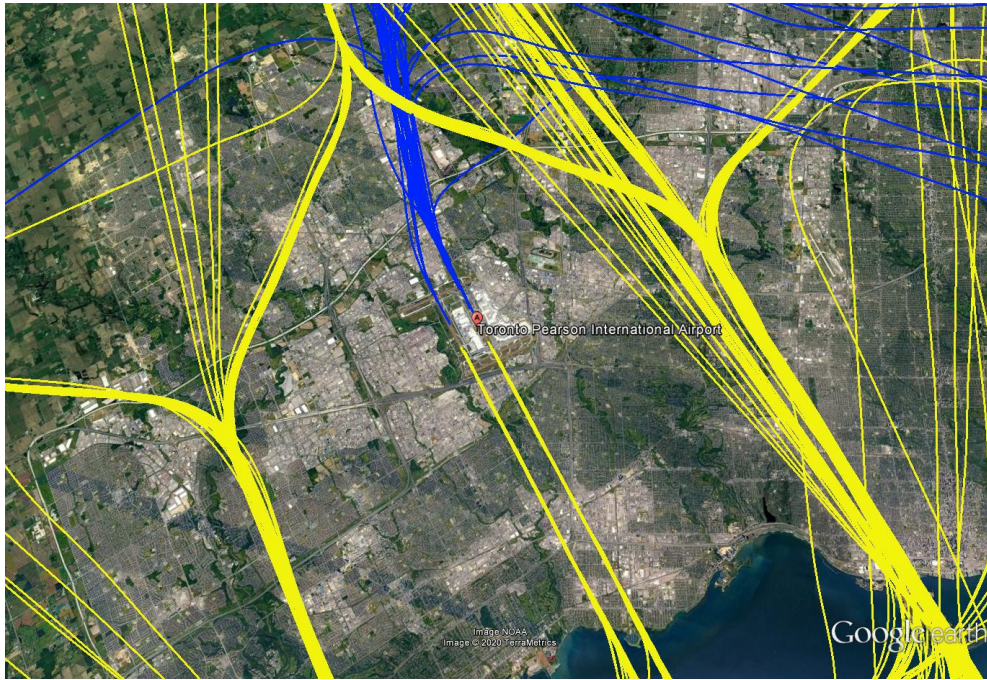

Arrivals on 33L and departures on 33R, some arrivals on 33R

Arrivals on 15L and departures 15R, some arrivals on 15R, some departures 15L

- **North** – Brampton East, Brampton Centre, Brampton North, Mississauga-Malton
- **South** – Etobicoke Centre, Etobicoke-Lakeshore, Mississauga East-Cooksville

Project 2: Rehabilitation of Runway 15L/33R - Phase 1 (Orange)

Date: Start upon completion of Phases 3 and 2

Duration: 35 days and nights for all 3 phases combined

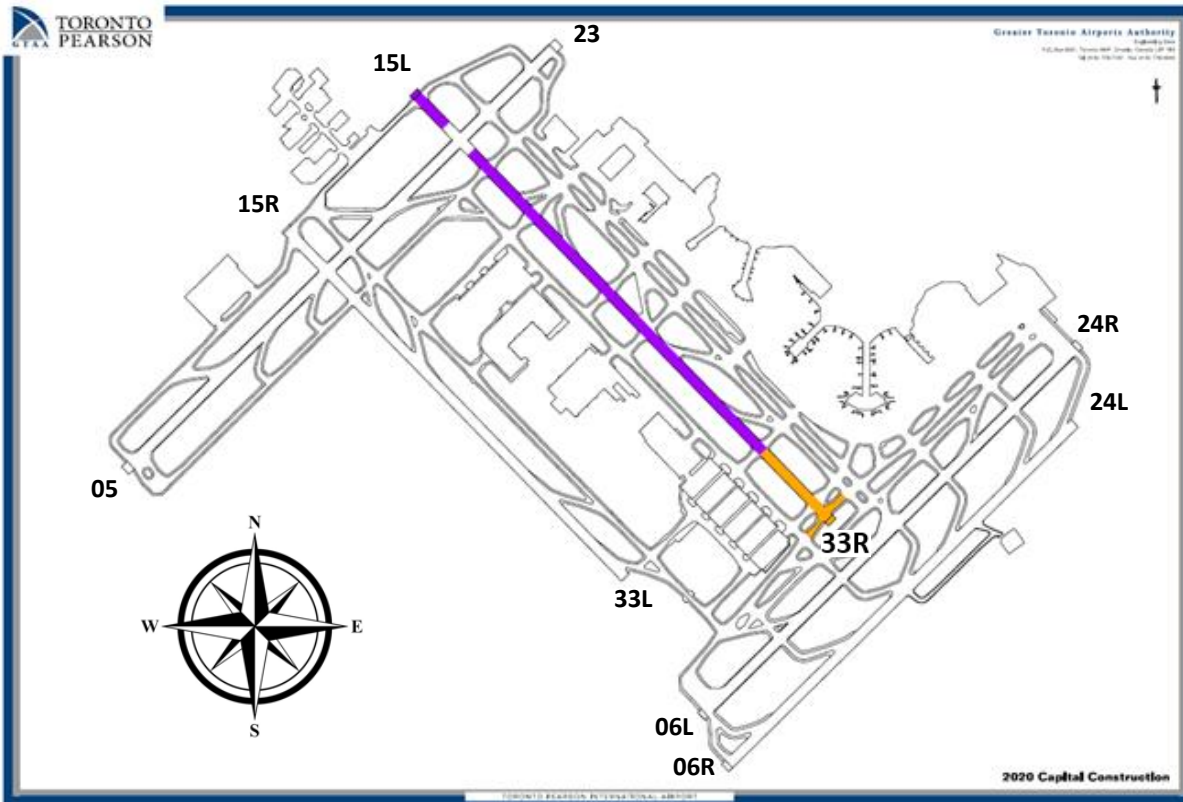

The Work

- Full length mill and pave of the runway to maintain a safe and stable surface
- Runway 33R is reopened for departures from Taxiway T only

Preferential hours (midnight to 6:29 a.m.) - Increased usage of maintenance contingency preferential runways

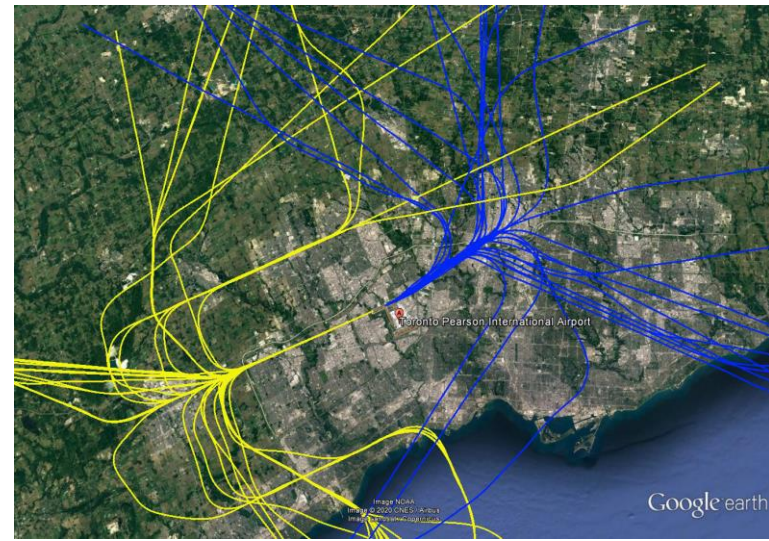
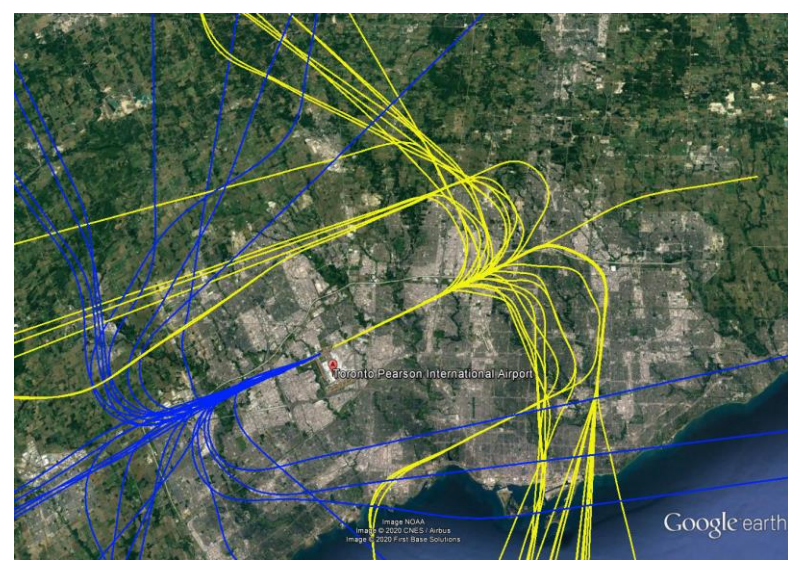

Arrivals and departures on 05 or 23

- **East** – Etobicoke North, Humber River Black Creek, Vaughan Woodbridge, Willowdale, Thornhill, Richmond Hill, Markham Unionville
- **West** – Mississauga-Malton, Mississauga-Streetsville, Mississauga-Erin Mills, Brampton South, Milton

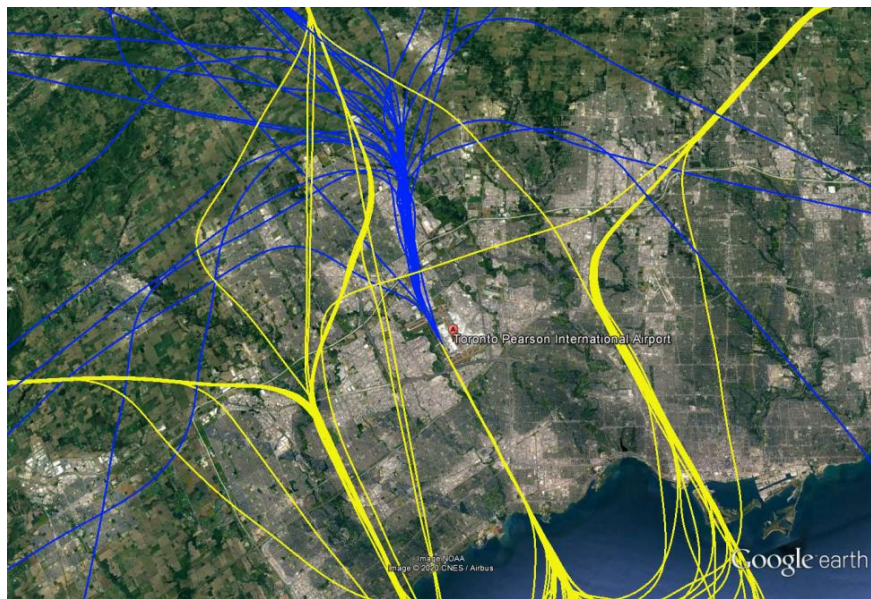

Arrivals 33L and departures 33R if required by winds

- **South** – Etobicoke Centre, Etobicoke Lakeshore, Mississauga East-Cooksville
- **North** – Brampton East, Brampton Centre, Brampton North, Mississauga-Malton

Timeline

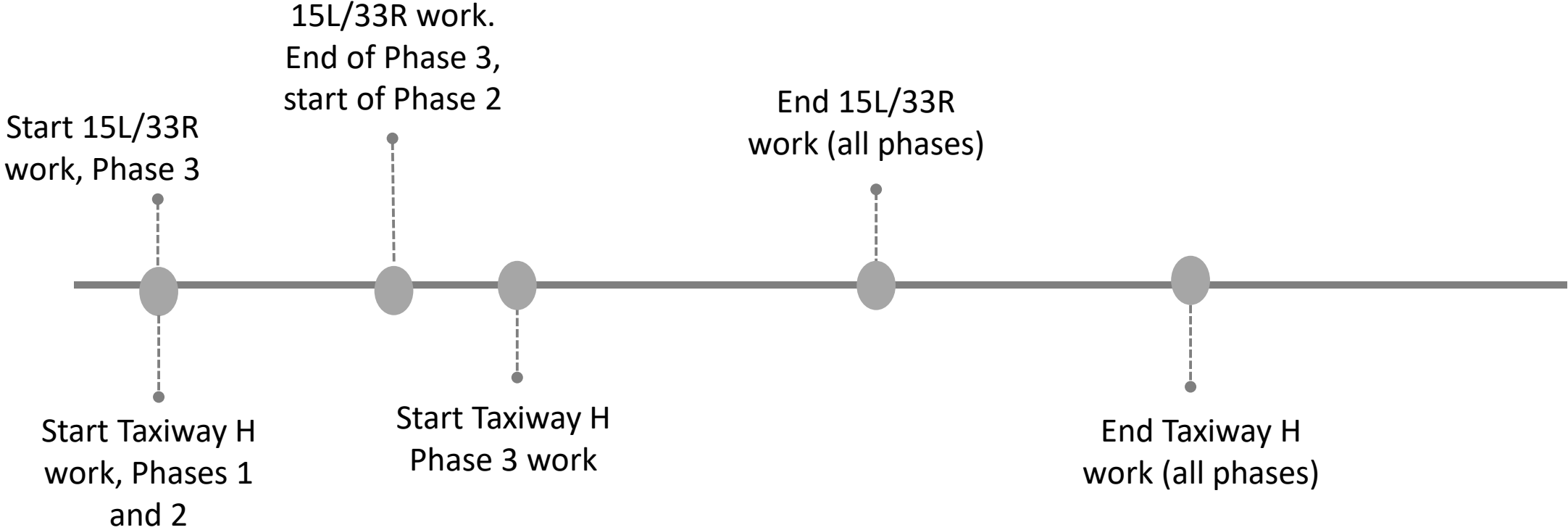

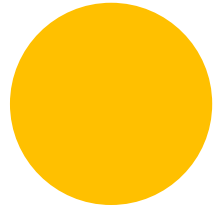
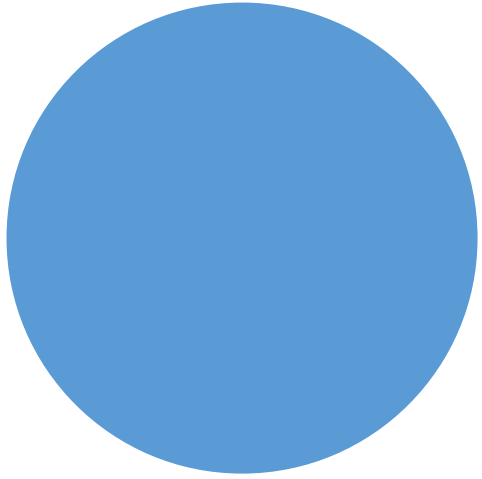

Thank You

